

5	Contact	Stainless Steel	Ag Clad	
4	Terminal	Brass	Ag Plating	
3	Cover	SPCC	Sn Plating	
2	Stem	PPA		UL94HB, Red
1	Case	PPA		UL94HB, Black
No.	Name	Material	Finish	Remarks

Part No.	Height	Package
STS-221	H=3.8mm	2,000 Pcs/Reel
STS-221-B1	H=5.0mm	1,500 Pcs/Reel
STS-221-D1	H=7.0mm	1,000 Pcs/Reel

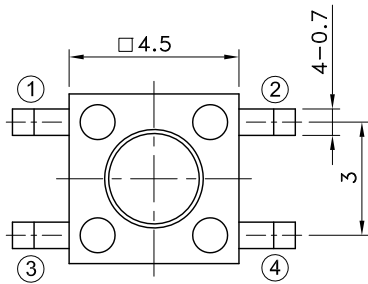

SET MAREKR KNOB SIZE  
(H:3.8mm ONLY)

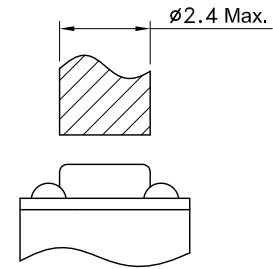
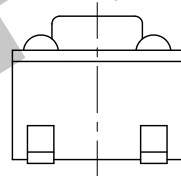
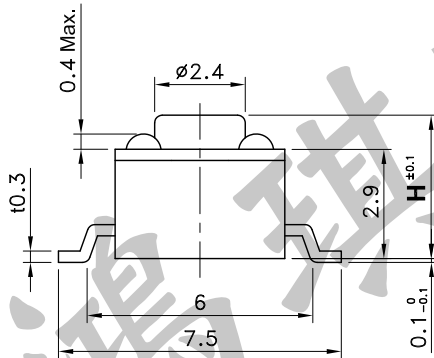

### P.C.B TERMINAL POSITION

### CIRCUIT ARRANGEMENT

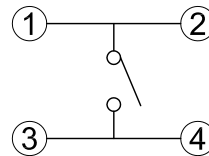
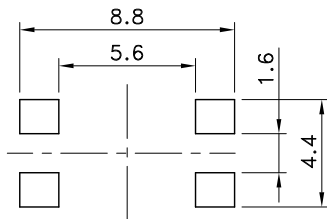

### SOLDERING CONDITIONS

### SPECIFICATIONS

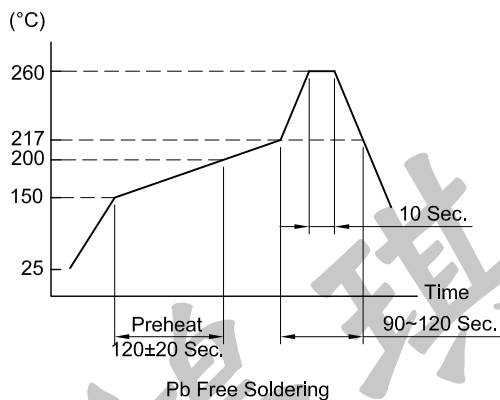

- Rating : DC 12V 50mA
- Contact Resistance : 100mΩ Max.
- Insulation Resistance : 100MΩ Min. at DC 100V
- Dielectric strength : AC 250V for 1 Minute
- Operating Force : 260±50 gf
- Stroke : 0.2±0.1 mm
- Life : 200,000 Cycles
- Operating Temperature Range : -20~+70°C
- Storage Temperature Range : -30~+80°C
- Manual soldering : Tip Temperature 350±5°C  
Soldering Time 5 Sec.

REVISION: \_\_\_\_\_ DATE: \_\_\_\_\_ REVISION: \_\_\_\_\_ DATE: \_\_\_\_\_

UNIT:mm THIRD ANGLE PROJECTION METHOD TOL. UNLESS OTHERWISE STATED:±0.2 CODE NO.: HCH-2483

ISSUED	CONFIRMED	 <b>HORNG CHIH</b> 鴻琪股份有限公司	PART NO.
<i>John</i> 2022.05.31	<i>Elvis</i> 2022.05.31		<b>STS-221</b>