

Part No.	Operating Force	Life
STS-108-B	240±60gf	500,000 Cycles
STS-108-C	340±100gf	100,000 Cycles

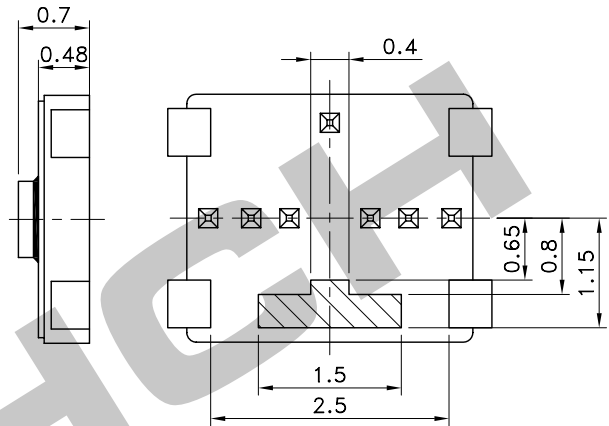

P.C.B TERMINAL POSITION

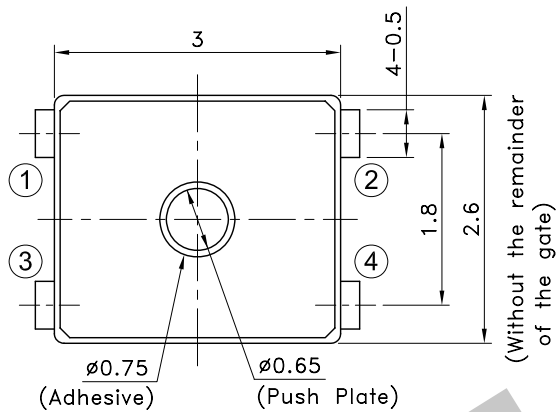
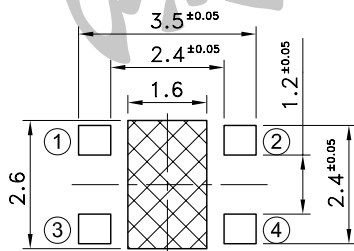

Part of ③ - ④ terminal is exposed at area.
Any land pattern or vias shall not be provided at area.

SOLDERING CONDITIONS

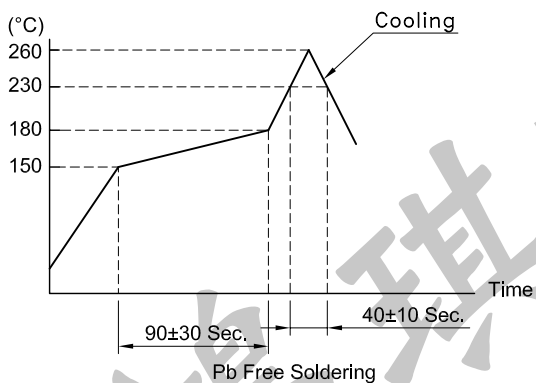

CIRCUIT ARRANGEMENT

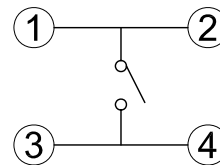
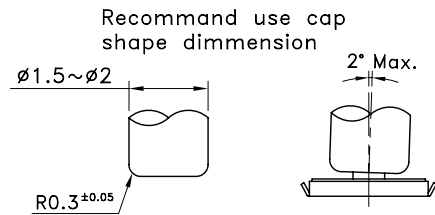

SPECIFICATIONS

- Rating : DC2V 10μA ~ DC15V 20mA
- Contact Resistance : 500mΩ Max.
- Insulation Resistance : 50MΩ Min. at DC 100V
- Dielectric strength : AC 250V for 1 Minute
- Stroke : 0.15±0.1 mm
- Package : 8,000 Pcs/Reel
- Operating Temperature Range : -40~+85°C
- Storage Temperature Range : -40~+85°C (Bulk)
-20~+60°C (Taping)
- Reflow soldering : According Reflow Profile
Max. 2 Times. Re-soldering by soldering iron shall be allowed under 280°C max. 3 sec.

REVISION:		DATE:		REVISION:		DATE:	
UNIT:mm		THIRD ANGLE PROJECTION METHOD		TOL. UNLESS OTHERWISE STATED:±0.1		CODE NO.:HCH-1924	
ISSUED		CONFIRMED		PART NO.		STS-108	
John		Elvis		HCH® HORNG CHIH			
2014.01.15		2014.01.15		ISO9001 Certified ISO14001 Certified 鴻琪股份有限公司			