

Part No.	Operating Force	Life
STS-070-A	160±50gf	1,000,000 cycle
STS-070-B	240±60gf	500,000 cycle
STS-070-C	350±100gf	200,000 cycle

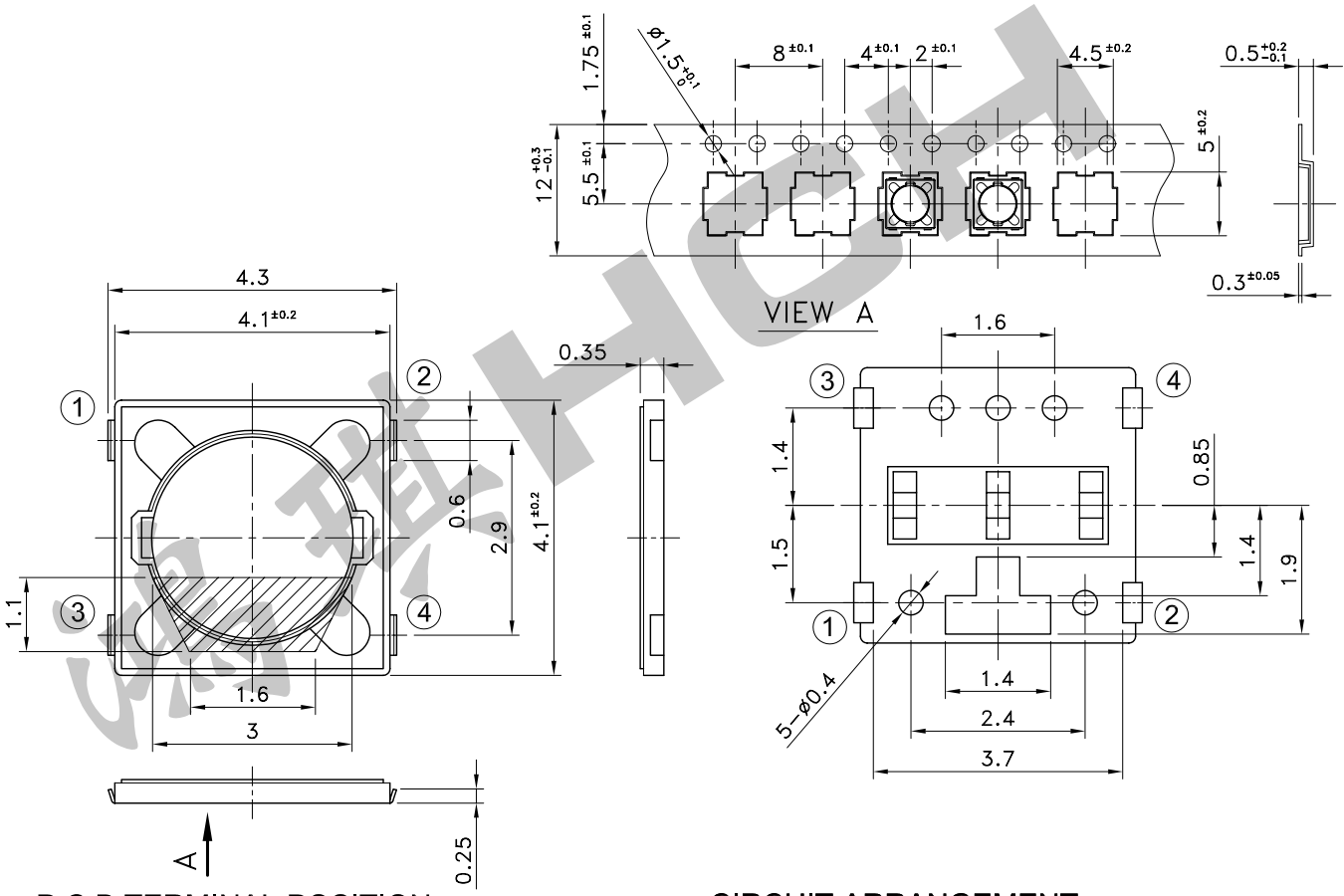

P.C.B TERMINAL POSITION

CIRCUIT ARRANGEMENT

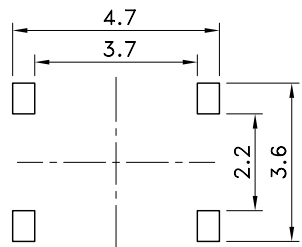

SOLDERING CONDITIONS

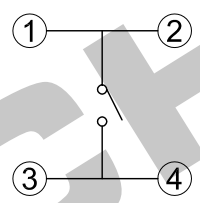

SPECIFICATIONS

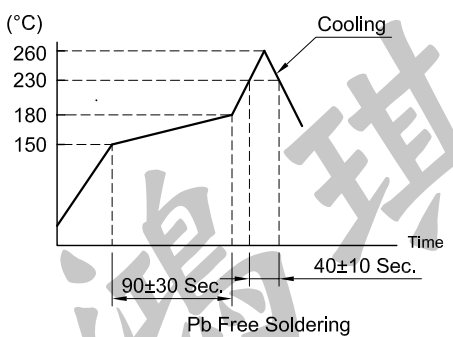

1. Rating : DC15V 20mA~DC2V 10µA
2. Contact Resistance : 100mΩ Max.
3. Insulation Resistance : 50MΩ Min.
4. Dielectric Strength : AC 100V for 1 Minute
5. Stroke : 0.2±0.1 mm
6. Taping Packing : 10,000 Pcs/Reel
7. Operating Temperature Range : -20 ~ +70°C

REVISION:		DATE:		REVISION:		DATE:	
UNIT:mm		THIRD ANGLE PROJECTION METHOD		TOL. UNLESS OTHERWISE STATED:±0.3		CODE NO.:HCH-339-3	
ISSUED		CONFIRMED		HCH [®] ISO9001 Certified ISO14001 Certified HORNG CHIH 鴻琪股份有限公司		PART NO. STS-070	
<i>John</i> 2008.05.29		<i>Elvis</i> 2008.05.29					