

6	Dust Cover	PTFE	
5	Terminal	Brass C2680	Ag Plated
4	Contact	SUS301	Ag Plated
3	Cover	SUS304	
2	Case	PA6T	
1	Push Plate	PA6T	
No.	Parts	Material	Remarks

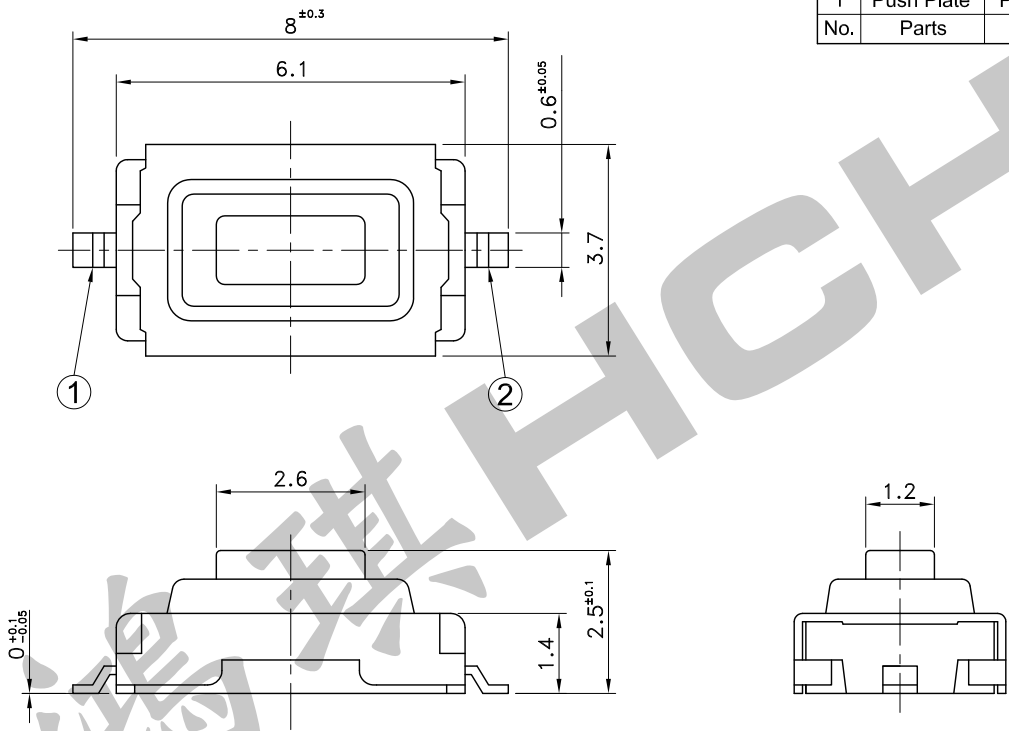

P.C.B TERMINAL POSITION

CIRCUIT ARRANGEMENT

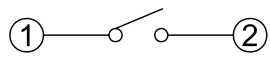
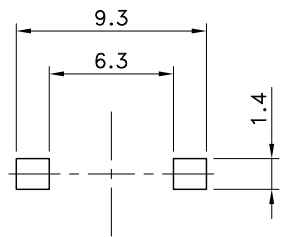

REFLOW SOLDERING CONDITIONS

SPECIFICATIONS

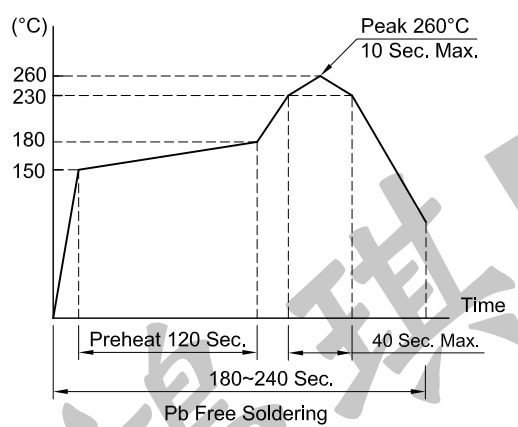

1. Rating : DC 12V 50mA
2. Contact Resistance : 100mΩ Max.
3. Insulation Resistance : 100MΩ Min. at DC 100V
4. Dielectric strength : AC 250V for 1 Minute
5. Operating Force : 260±50gf
6. Stroke : 0.25±0.1mm
7. Life : 30,000 Cycles
8. Taping package : 3,000 Pcs/Reel
9. Operation Temperature Range : -20~+70°C
10. Storage Temperature Range : -30~+80°C

REVISION:		DATE:		REVISION:		DATE:	
UNIT:mm		THIRD ANGLE PROJECTION METHOD		TOL. UNLESS OTHERWISE STATED:±0.2		CODE NO.: HCH-1431-4	
ISSUED		CONFIRMED		HCH HORNG CHIH ISO9001 Certified ISO14001 Certified 鴻琪股份有限公司		PART NO. STS-04-DB	
<i>John</i> 2014.09.12		<i>Elvis</i> 2014.09.12					