

P.C.B TERMINAL POSITION

CIRCUIT ARRANGEMENT

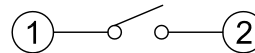
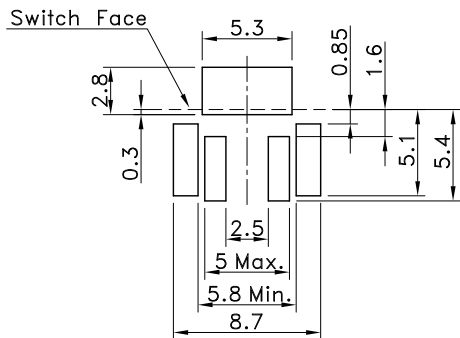

SOLDERING CONDITIONS

SPECIFICATIONS

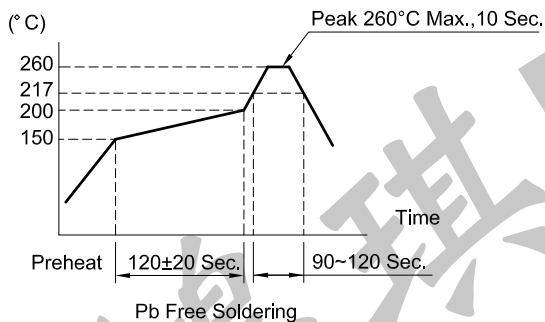

1. Rating : DC 12V 50mA
2. Contact Resistance : 100mΩ Max.
3. Insulation Resistance : 100MΩ Min. at DC 100V
4. Dielectric Strength : AC 250V for 1 Minute
5. Operating Force : 180±50gf
6. Stroke : 0.35±0.2 mm
7. Life : 200,000 Cycles
8. Package : 600 Pcs/Reel
9. Operating Temperature Range : -20~+70°C
10. Storage Temperature Range : -30~+80°C
11. Reflow Soldering Profile : According Reflow Profile 2 Times
12. Manual soldering : Tip Temperature 400°C Max.  
Soldering Time Within 4 Sec.

REVISION:		DATE:		REVISION:		DATE:	
UNIT:mm		THIRD ANGLE PROJECTION METHOD		TOL. UNLESS OTHERWISE STATED:±0.3		CODE NO.:HCH-1541-4 (N)	
ISSUED		CONFIRMED		PART NO.		PTS-160	
John		Elvis		HCH® HORNG CHIH ISO9001 Certified ISO14001 Certified 鴻琪股份有限公司			
2017.11.07		2017.11.07					