

Part No.	Operating Force	Life
PTS-01-A	75 gf Max.	5,000,000 Cycles
PTS-01-B	130 gf Max.	1,000,000 Cycles

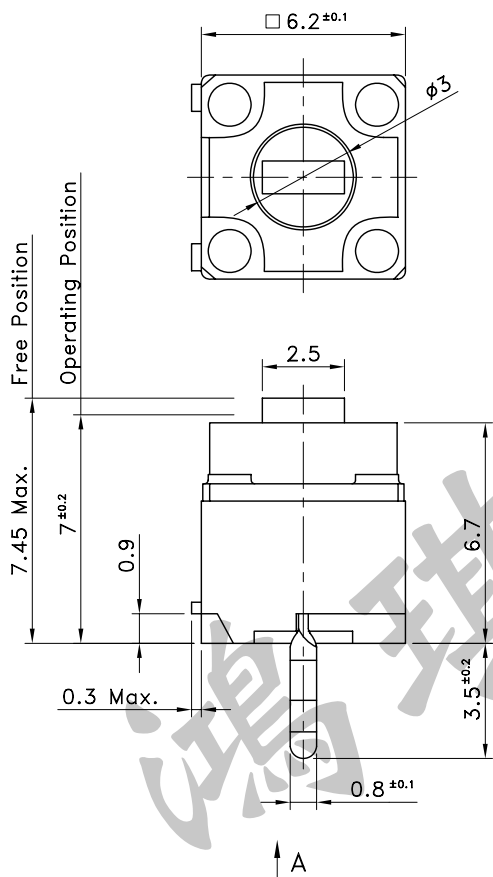

P.C.B TERMINAL POSITION

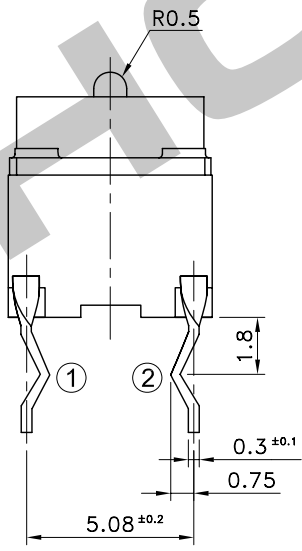

CIRCUIT ARRANGEMENT

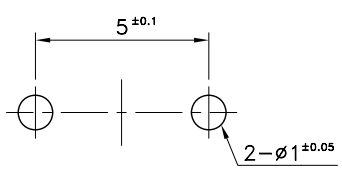
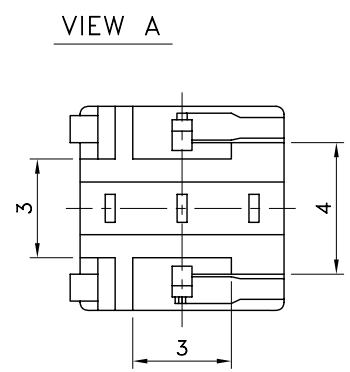

SOLDERING CONDITIONS

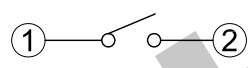

SPECIFICATIONS

1. Rating : DC 30V 50 mA
2. Contact Resistance : 100mΩ Max.
3. Insulation Resistance : 100MΩ Min. at DC 100V
4. Dielectric Strength : AC 600V for 1 Minute
5. Stroke : 0.5mm Max.
6. Operating Temperature Range : -25~+65°C
7. Storage Temperature Range : -45~+85°C

	Temperature (°C)	Time (Sec.)
Manual Soldering	280 Max.	3 Max.

REVISION:		DATE:		REVISION:		DATE:	
UNIT:mm	THIRD ANGLE PROJECTION METHOD	TOL. UNLESS OTHERWISE STATED:±0.2		CODE NO.: HCH-972-1 (P)			
ISSUED	CONFIRMED	<b>HORNG CHIH</b> HONG CHIH 鴻琪股份有限公司 				PART NO.	
John	Elvis					PTS-01-A	
2014.01.28	2014.01.28						