

7	Terminal 6	Phosphor Bronze	1	Ag Plating	
6	Terminal 5	Phosphor Bronze	1	Ag Plating	
5	Terminal 4	Phosphor Bronze	1	Ag Plating	
4	Terminal 3	Phosphor Bronze	1	Ag Plating	
3	Terminal 2	Phosphor Bronze	1	Ag Plating	
2	Terminal 1	Phosphor Bronze	1	Ag Plating	
1	Housing	PA	1		Black
No.	Parts	Material	Q'ty	Finish	Remarks

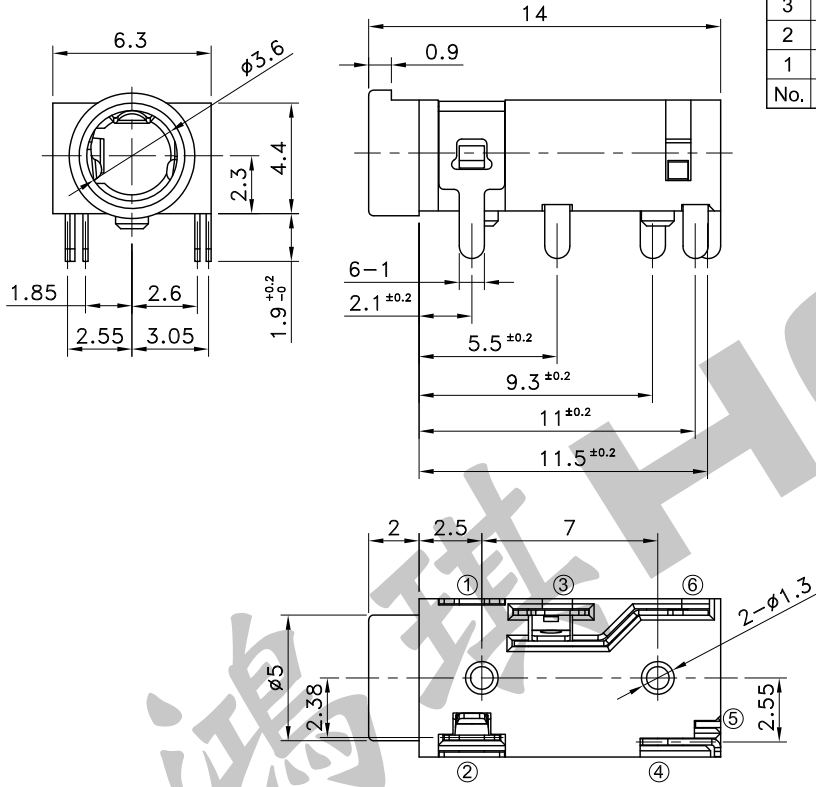

**P.C.B TERMINAL POSITION**

**CIRCUIT ARRANGEMENT**

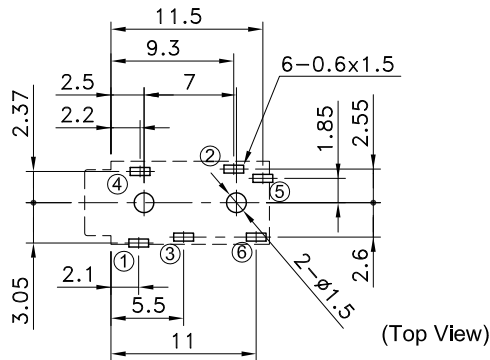
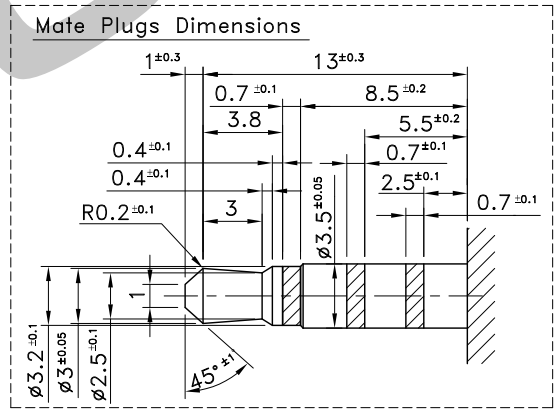

**SOLDERING CONDITIONS**

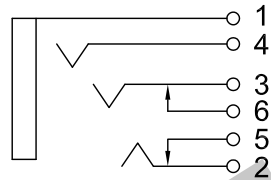

**SPECIFICATIONS**

- Rating : DC 30V 0.5A
- Contact Resistance : 30mΩ Max.
- Insulation Resistance : 100MΩ Min.at DC 250V
- Dielectric Strength : AC 500V for 1 minute
- Insertion & Extraction Force : 0.3~3.0 kgf
- Life : 5,000 Cycles
- Operating Temperature Range : -20~+70°C
- Storage Temperature Range : -20~+60°C

	Temperature (°C)	Time (Sec.)
Auto Soldering	255~260 Max.	5~10
Manual Soldering	350±5	3±0.5 Max.

REVISION:	DATE:	REVISION:	DATE:
UNIT:mm	THIRD ANGLE PROJECTION METHOD	TOL. UNLESS OTHERWISE STATED:±0.3	CODE NO.:HCH-2502
ISSUED	CONFIRMED	PART NO.	
<i>John</i>	<i>Elvis</i>	<b>PJK-493B</b>	
2022.09.23	2022.09.23	<b>HCH</b> ISO9001 Certified ISO14001 Certified <b>HORNG CHIH</b> 鴻琪股份有限公司	