

4	Terminal 3	Copper Alloy	Tin Plated
3	Terminal 2	Copper Alloy	Tin Plated
2	Terminal 1	Copper Alloy	Tin Plated
1	Body	PA	
No.	Parts	Material	Finish

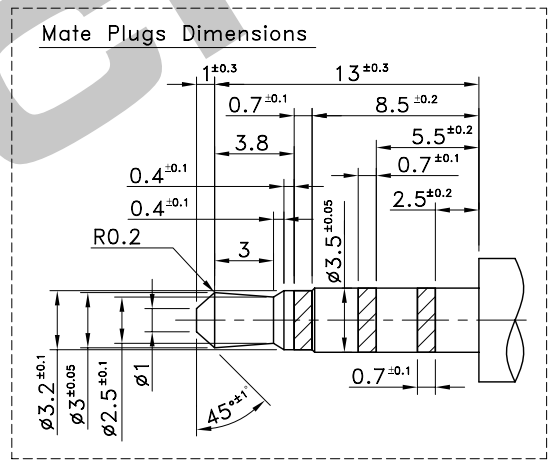

P.C.B TERMINAL POSITION

CIRCUIT ARRANGEMENT

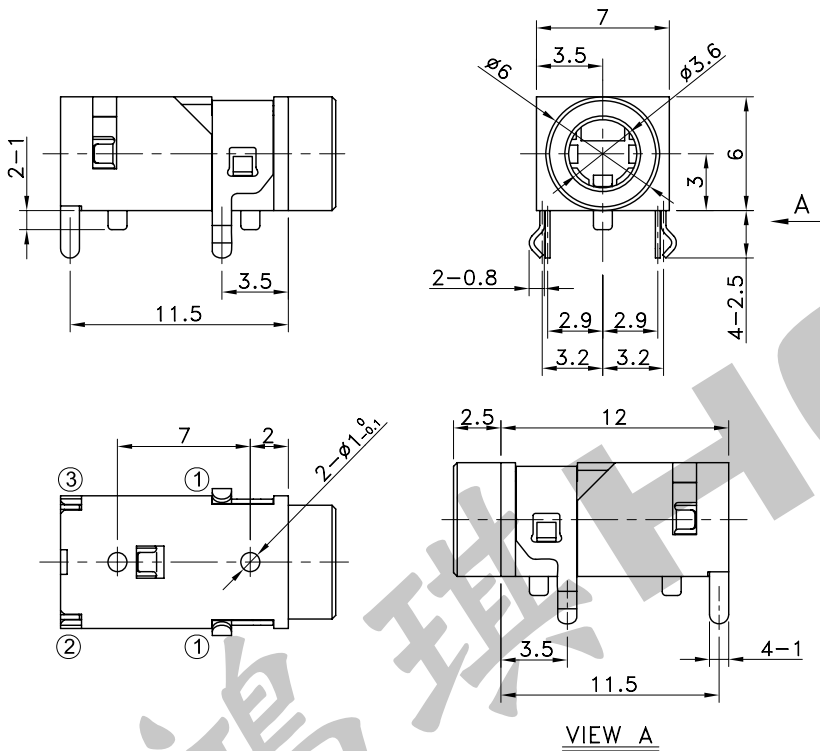
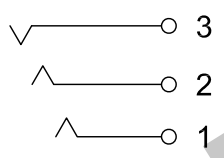
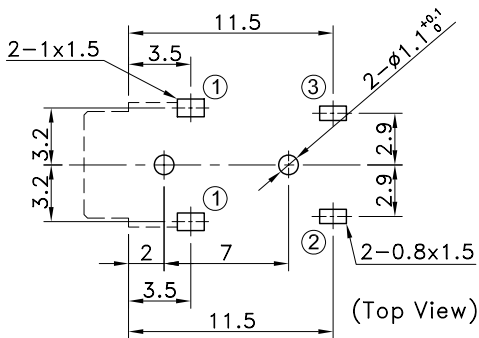

SOLDERING CONDITIONS

SPECIFICATIONS

	Temperature (°C)	Time (Sec.)
Auto Soldering	260±5	5±0.5

- Rating : DC 12V 1A Max.
- Contact Resistance : 50mΩ Max.
- Insulation Resistance : 100MΩ Min. at DC 500V
- Dielectric Strength : AC 500V for 1 Minute
- Insertion & Extraction Force : 0.3~3kgf
- Life : 5,000 Cycles
- Operating Temperature Range : -25~+85°C

REVISION:		DATE:		REVISION:		DATE:	
UNIT:mm		THIRD ANGLE PROJECTION METHOD		TOL. UNLESS OTHERWISE STATED:±0.3		CODE NO.:HCH-1740	
ISSUED		CONFIRMED		PART NO.		PJK-402	
John		Elvis		HCH® HORNG CHIH ISO9001 Certified ISO14001 Certified 鴻琪股份有限公司			
2011.05.03		2011.05.03					