

5	Terminal 4	Brass	Tin Plated
4	Terminal 3	Copper Alloy	Tin Plated
3	Terminal 2	Copper Alloy	Tin Plated
2	Terminal 1	Copper Alloy	Tin Plated
1	Body	PA	
No.	Parts	Material	Finish

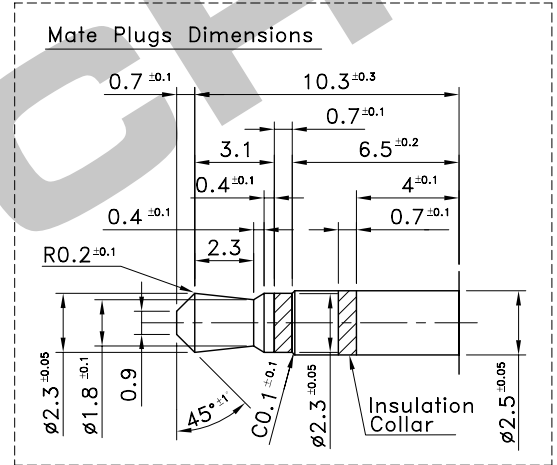

P.C.B TERMINAL POSITION

CIRCUIT ARRANGEMENT

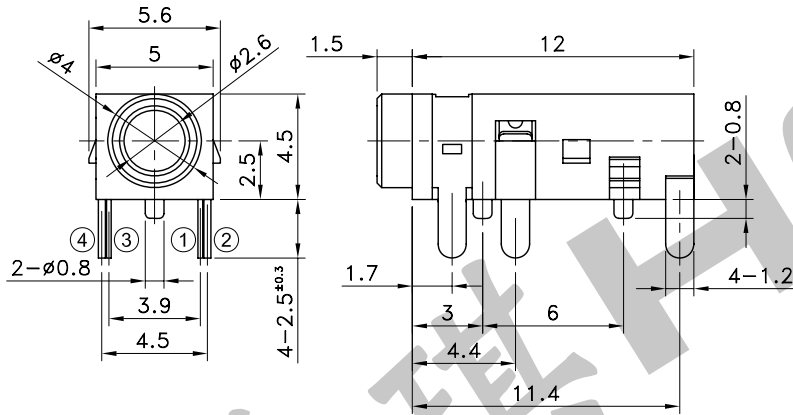
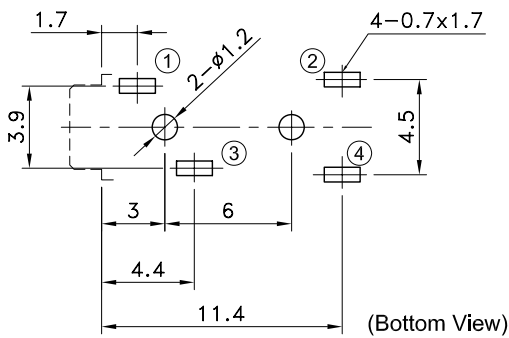

Part No.	Circuit Diagram	Terminal Arrangement Figure
PJK-327		
PJK-328		
PJK-329		

SOLDERING CONDITIONS

	Temperature (°C)	Time (Sec.)
Auto Soldering	260±5	5±0.5

SPECIFICATIONS

- Rating : DC 12V 1A Max.
- Contact Resistance : 50mΩ Max.
- Insulation Resistance : 100MΩ Min. at DC 500V
- Dielectric Strength : AC 500V for 1 Minute
- Insertion & Extraction Force : 0.3~3kgf
- Life : 5,000 Cycles
- Operating Temperature Range : -25~+85°C

REVISION:	DATE:	REVISION:	DATE:
UNIT:mm	THIRD ANGLE PROJECTION METHOD	TOL. UNLESS OTHERWISE STATED:±0.3	CODE NO.:HCH-1605
ISSUED	CONFIRMED	PART NO.	
<i>John</i>	<i>Elvis</i>	PJK-327 PJK-328	
2010.03.04	2010.03.04	PJK-329	
		HORNG CHIH 鴻琪股份有限公司	