

11	Emi Shell-2	t:0.1	Stainless Steel	1	NONE	
10	Emi Shell-1	t:0.1	Stainless Steel	1	NONE	
9	Mid Plate	t:0.15	Stainless Steel	1	Contact Area: Sn 40~100u" Solder Tails: 100u" Max. Sn	
8	Shell-2	t:0.3	Stainless Steel	1	50u" Min. Solderable Ni	
7	Shell-1	t:0.2	Stainless Steel	1	NONE	
6	Contact (SMT)	t:0.1	Copper Alloy	12	Contact Area: G/F (Au 0.8u" Min.) Under Plated Ni 50~180u" Solder Tails: Matte Sn 100~200u" Under Plated Ni 50~180u"	
5	Contact (DIP)	t:0.1	Copper Alloy	12		
4	Housing-4 (P4)		High Temp. Plastic	1		UL94V-0, Black
3	Housing-3 (P3)		High Temp. Plastic	1		UL94V-0, Black
2	Housing-2 (P2)		High Temp. Plastic	1		UL94V-0, Black
1	Housing-1 (P1)		High Temp. Plastic	1		UL94V-0, Black
No.	Parts		Material	Q'ty	Finish	Remarks

DETAIL B

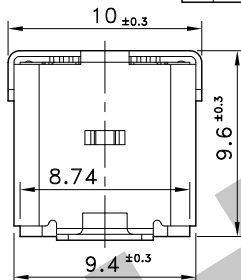
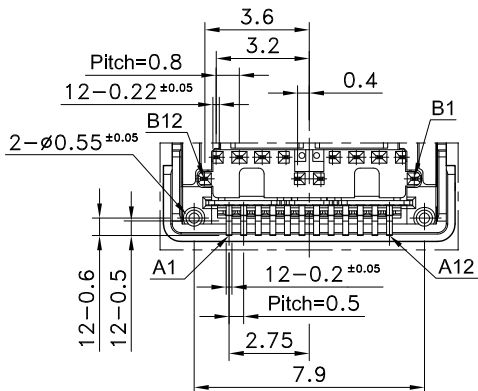

SECT. C-C

Pin	Signal Name	Mating Sequence	Pin	Signal Name	Mating Sequence
A1	GND	First	B12	GND	First
A2	SSTXp1	Second	B11	SSRXp1	Second
A3	SSTXn1	Second	B10	SSRXn1	Second
A4	Veus	First	B9	Veus	First
A5	CC1	Second	B8	SBU2	Second
A6	Dp1	Second	B7	Dn2	Second
A7	Dn1	Second	B6	Dp2	Second
A8	SBU1	Second	B5	CC2	Second
A9	Veus	First	B4	Veus	First
A10	SSRXn2	Second	B3	SSTXn2	Second
A11	SSRXp2	Second	B2	SSTXp2	Second
A12	GND	First	B1	GND	First
SHELL	GND		SHELL	GND	

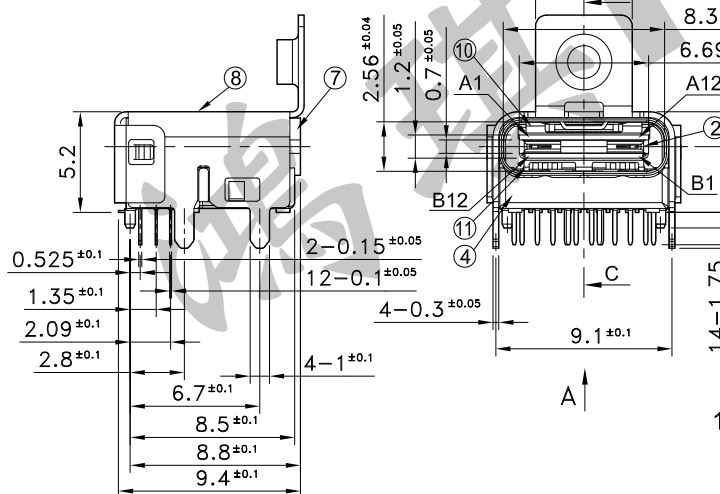

P.C.B TERMINAL POSITION

SPECIFICATIONS

- Rating : AC/DC 30V
Power Pins Collectively (Pins A1,A4,A9,A12,B1,B4,B9,B12): 5A
Vconn Pin (B5): 1.25A
Signal Pins (Other): 0.25A
- Contact Resistance : 40mΩ Max.
- Insulation Resistance : 100MΩ Min.
- Dielectric Strength : AC 100V for 1 Minute
- Insertion Force : 0.5~2 kgf
- Extract Force : 0.8~2 kgf
- Life : 10,000 Cycles
- Package : 300 Pcs/Reel
- Operating Temperature Range : -30~+85°C
- Storage Temperature Range : -40~+85°C

SOLDERING CONDITIONS

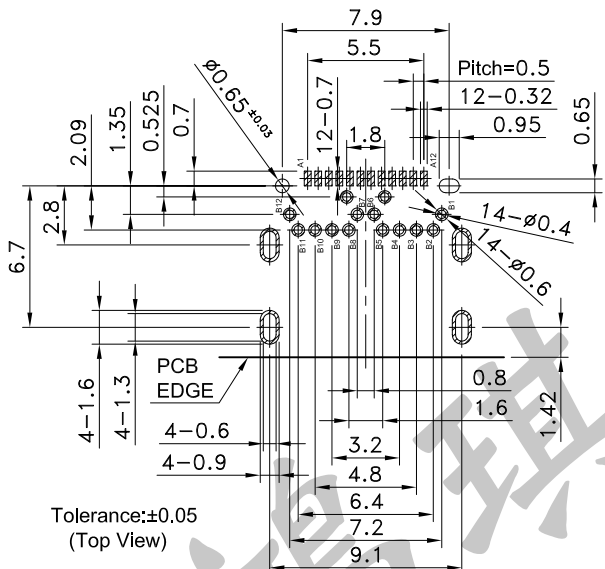
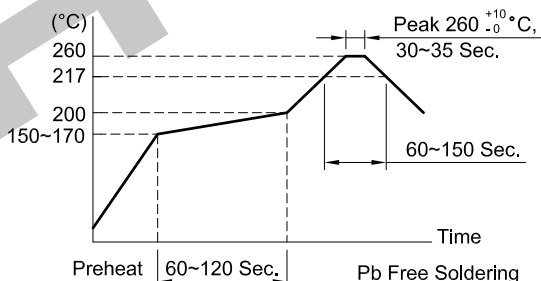

Tolerance:±0.05 (Top View)

REVISION:	DATE:	REVISION:	DATE:
UNIT:mm	THIRD ANGLE PROJECTION METHOD	TOL. UNLESS OTHERWISE STATED:±0.2	CODE NO.: HCH-2308-1
ISSUED	CONFIRMED	PART NO.	
John	Elvis	MUSB-863AB	
2019.11.12	2019.11.12	HORNG CHIH 鴻琪股份有限公司	