

4	Insulator	LCP	
3	Housing	PA10T	
2	Shell	Stainless Steel	Nickel Plated
1	Terminals	Copper Alloy	Nickel plated on all area, Gold flash on contact & solder area
No.	Parts	Material	Finish

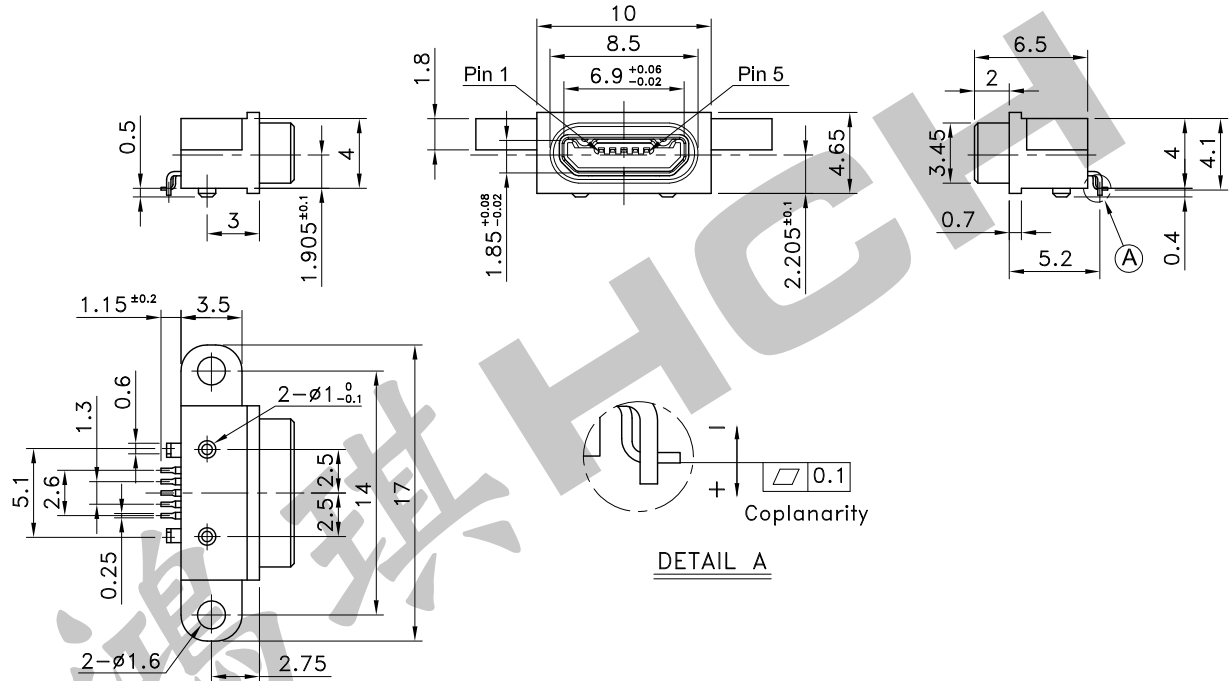

P.C.B TERMINAL POSITION

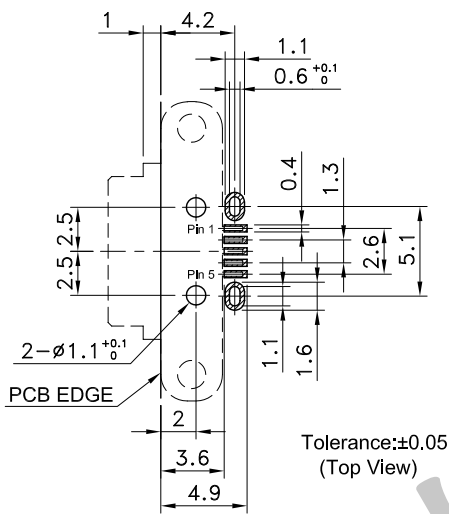

SPECIFICATIONS

- Rating : AC 30V 1.8A Max. (Pin 1 , 5)
AC 30V 0.5A Max. (Pin 2 , 3 , 4)
- Contact Resistance : 30m Ω Max.
- Insulation Resistance : 100M Ω Min.
- Dielectric Strength : AC 250V for 1 Minute
- Insertion Force : 3.5kgf Max.
- Extract Force : 0.8kgf Min.
- Life : 10,000 Cycles
- Operating Temperature Range : -25~+85°C
- Storage Temperature Range : 0~+40°C
- Water Proof : IP67

SOLDERING CONDITIONS

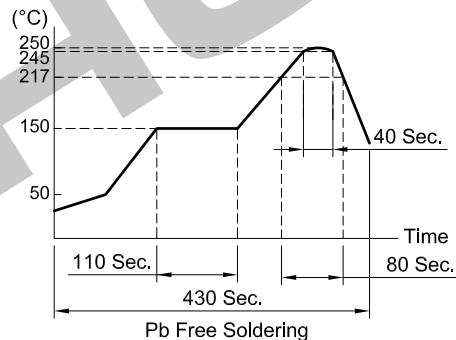

REVISION:	DATE:	REVISION:	DATE:
UNIT:mm	THIRD ANGLE PROJECTION METHOD	TOL. UNLESS OTHERWISE STATED: ± 0.2	CODE NO.: HCH-2314
ISSUED	CONFIRMED	PART NO.	
<i>John</i>	<i>Elvis</i>	MUSB-854BB	
2020.01.08	2020.01.08	HCH ISO9001 Certified ISO14001 Certified HORNG CHIH 鴻琪股份有限公司	