

4	Mylar		1	W=6.0mm	
3	Shell	Copper Alloy	1	Ni1	
2	Contact	Copper Alloy	5	G / F	
1	Housing	LCP	1		Black
No.	Parts	Material	Q'ty	Finish	Remarks

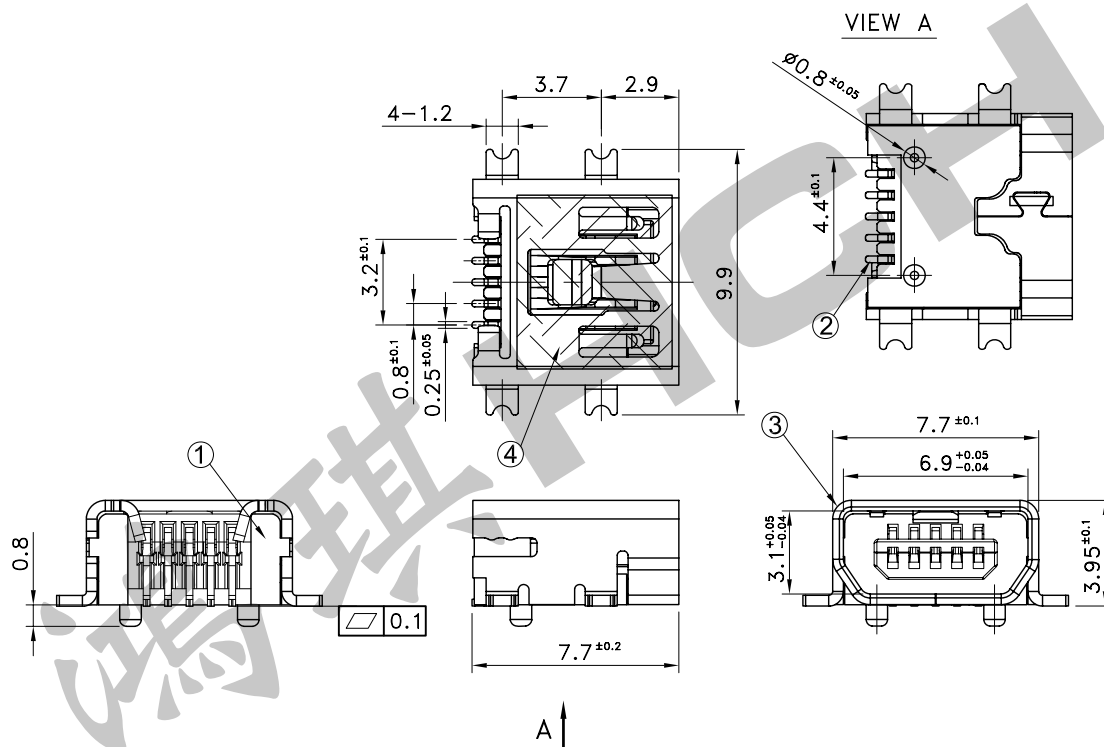

P.C.B TERMINAL POSITION

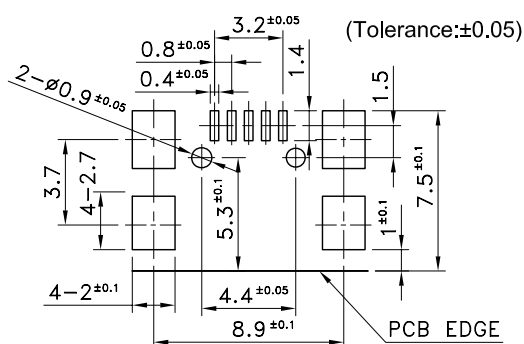

SPECIFICATIONS

- Rating : DC 30V 1A Max.
- Contact Resistance : 50mΩ Max.
- Insulation Resistance : 100MΩ Min. at DC 500V
- Dielectric Strength : AC 100V for 1 Minute
- Insertion Force : 3.57kgf Max.
- Extract Force : 0.71kgf Min.
- Life : 5,000 Cycles
- Package : 1,000 Pcs/Reel
- Operating Temperature Range : -20~+60°C
- Storage Temperature Range : -55~+85°C

SOLDERING CONDITIONS

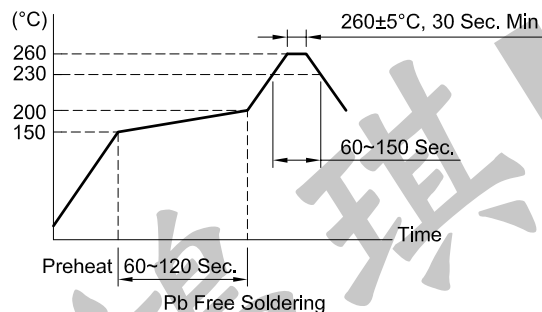

REVISION:		DATE:		REVISION:		DATE:	
UNIT:mm		THIRD ANGLE PROJECTION METHOD		TOL. UNLESS OTHERWISE STATED:±0.3		CODE NO.: HCH-1842	
ISSUED		CONFIRMED		HCH ISO9001 Certified ISO14001 Certified HORNG CHIH 鴻琪股份有限公司		PART NO. MUSB-821	
<i>John</i> 2012.05.29		<i>Elvis</i> 2012.05.29					