

# MICRO SWITCHES

**MQS-12D35**

- Rating: AC125V 5A (UL, cUL)  
AC125/250V 3A(ENEC, CQC)
- Force: 35±15gf
- Life: 6,000 Cycles (UL, cUL)  
50,000 Cycles (ENEC, CQC)

**Circuit**

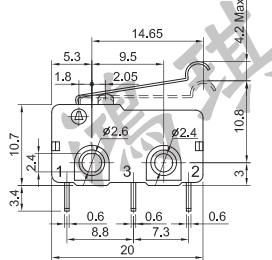
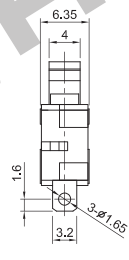

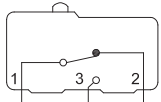
**Mounting Hole Layout**

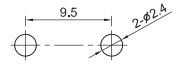

**MQS-12D35P**

- Rating: AC125V 5A (UL, cUL)  
AC125/250V 3A(ENEC, CQC)
- Force: 35±15gf
- Life: 6,000 Cycles (UL, cUL)  
50,000 Cycles (ENEC, CQC)

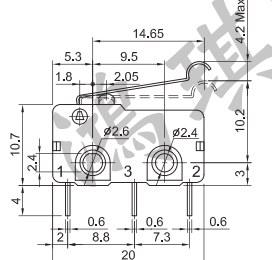
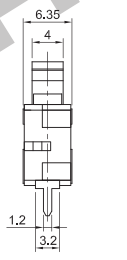
**Circuit**

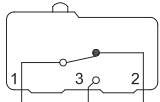

**Mounting Hole Layout**

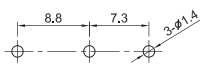

**MQS-12E20**

- Rating: AC125V 5A (UL, cUL)  
AC125/250V 3A(ENEC, CQC)
- Force: 35±15gf
- Life: 6,000 Cycles (UL, cUL)  
50,000 Cycles (ENEC, CQC)

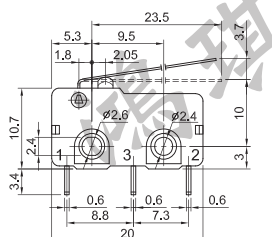
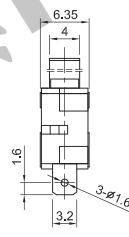
**Circuit**

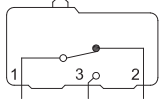

**Mounting Hole Layout**

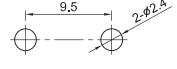

**MQS-12E20P**

- Rating: AC125V 5A (UL, cUL)  
AC125/250V 3A(ENEC, CQC)
- Force: 35±15gf
- Life: 6,000 Cycles (UL, cUL)  
50,000 Cycles (ENEC, CQC)

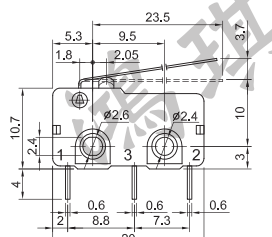
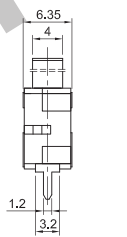
**Circuit**

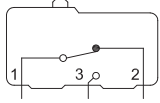

**Mounting Hole Layout**

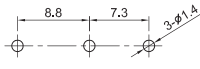

**MQS-12A30A**

- Rating: AC125V 5A (UL, cUL)  
AC250V 3A (ENEC, CQC)
- Force: 30±15gf
- Life: 6,000 Cycles (UL, cUL)  
50,000 Cycles (ENEC, CQC)

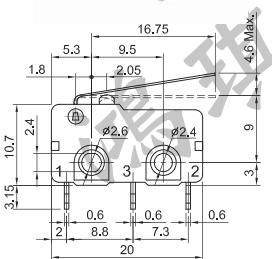
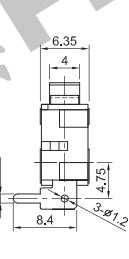
**Circuit**

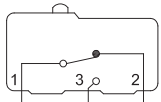

**Mounting Hole Layout**

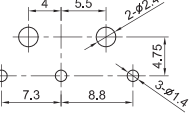

**MQS-12A30B**

- Rating: AC125V 5A (UL, cUL)  
AC250V 3A (ENEC, CQC)
- Force: 30±15gf
- Life: 6,000 Cycles (UL, cUL)  
50,000 Cycles (ENEC, CQC)

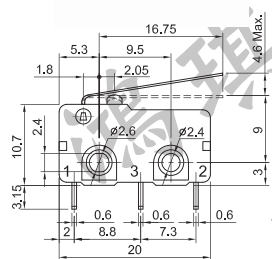
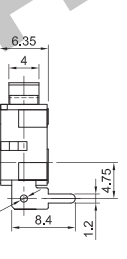
**Circuit**

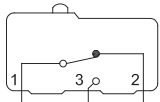

**Mounting Hole Layout**

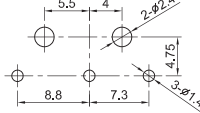

**MQS-12C30A**

- Rating: AC125V 5A (UL, cUL)  
AC125/250V 3A(ENEC, CQC)
- Force: 35±15gf
- Life: 6,000 Cycles (UL, cUL)  
50,000 Cycles (ENEC, CQC)

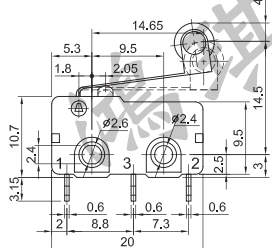
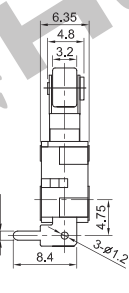
**Circuit**

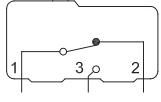

**Mounting Hole Layout**

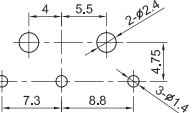

**MQS-12C30B**

- Rating: AC125V 5A (VDE, UL, cUL)  
AC250V 3A (CQC, VDE)  
AC250V 5A (UL, cUL)
- Force: 30±10gf
- Life: 6,000 Cycles (UL, cUL)  
50,000 Cycles (CQC, VDE)

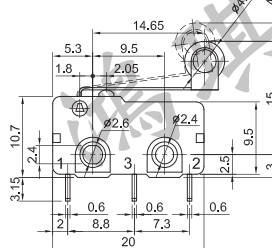
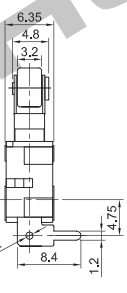
**Circuit**

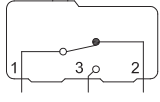

**Mounting Hole Layout**

