

MICRO SWITCHES

MQS-12120

- Rating: AC125V 5A (UL, cUL)
AC125/250V 3A(ENEC, CQC)
- Force: 130±30gf
- Life: 6,000 Cycles (UL, cUL)
50,000 Cycles (ENEC, CQC)



Circuit

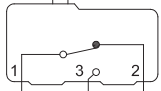

Mounting Hole Layout

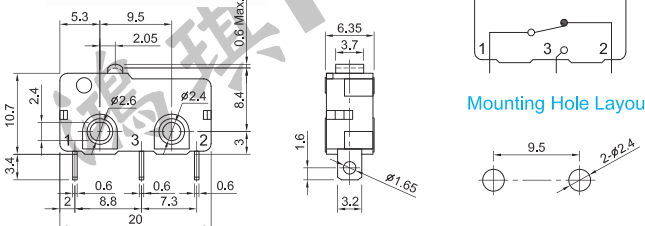

MQS-12120P

- Rating: AC125V 5A (UL, cUL)
AC125/250V 3A(ENEC, CQC)
- Force: 130±30gf
- Life: 6,000 Cycles (UL, cUL)
50,000 Cycles (ENEC, CQC)



Circuit

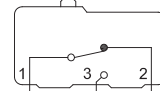

Mounting Hole Layout

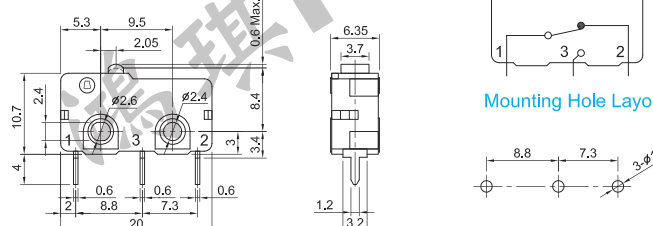

MQS-12A30

- Rating: AC125/250V 5A (UL, cUL)
AC125V 5A (VDE)
AC250V 3A (CQC, VDE)
- Force: 30±10gf
- Life: 6,000 Cycles (UL, cUL)
50,000 Cycles (CQC, VDE)



Circuit

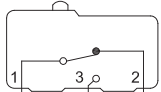

Mounting Hole Layout

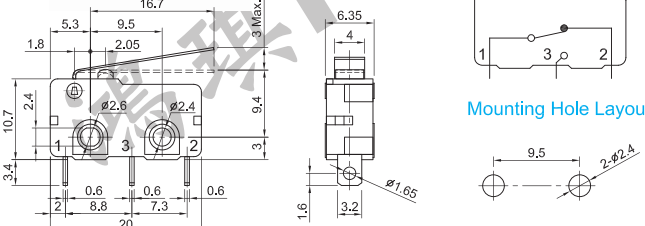

MQS-12A30P

- Rating: AC125V 5A (UL, cUL)
AC250V 3A (ENEC, CQC)
- Force: 30±15gf
- Life: 6,000 Cycles (UL, cUL)
50,000 Cycles (ENEC, CQC)



Circuit

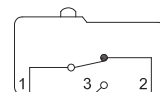

Mounting Hole Layout

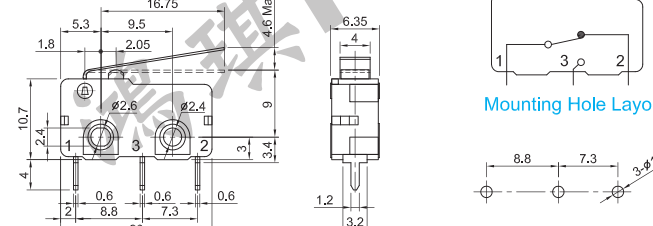

MQS-12B30

- Rating: AC125V 5A (UL, cUL)
AC125/250V 3A(ENEC, CQC)
- Force: 25±10gf
- Life: 6,000 Cycles (UL, cUL)
50,000 Cycles (ENEC, CQC)



Circuit

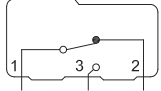

Mounting Hole Layout

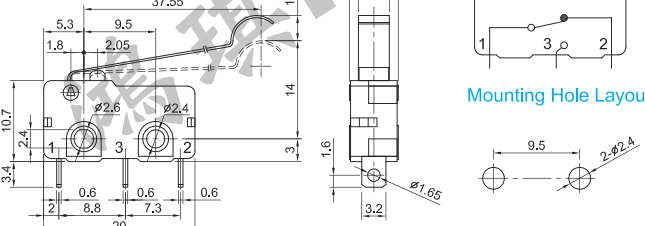

MQS-12B30P

- Rating: AC125V 5A (UL, cUL)
AC125/250V 3A(ENEC, CQC)
- Force: 25±10gf
- Life: 6,000 Cycles (UL, cUL)
50,000 Cycles (ENEC, CQC)



Circuit



Mounting Hole Layout

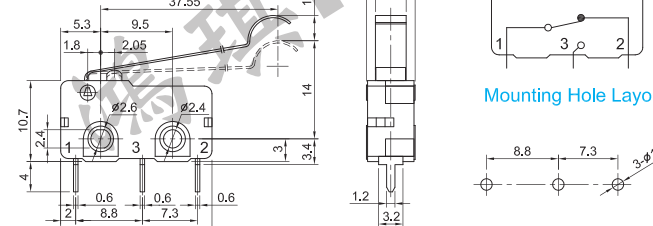

MQS-12C30

- Rating: AC125V 5A (UL, cUL)
AC125/250V 3A(ENEC, CQC)
- Force: 35±15gf
- Life: 6,000 Cycles (UL, cUL)
50,000 Cycles (ENEC, CQC)



Circuit

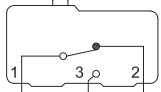

Mounting Hole Layout

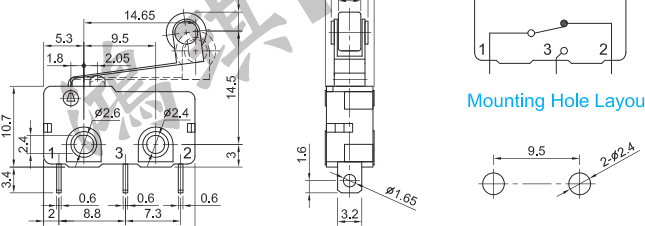

MQS-12C30P

- Rating: AC125V 5A (UL, cUL)
AC125/250V 3A(ENEC, CQC)
- Force: 35±15gf
- Life: 6,000 Cycles (UL, cUL)
50,000 Cycles (ENEC, CQC)



Circuit

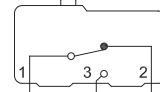

Mounting Hole Layout

